

2 OPTIONAL ACCESSORIES

**ON-BOARD VACUUM HOSE KIT**

**P/N 900998.**

4" (102mm) x 7' (2.13m) w/wear strip

*For vacuuming in hard to reach areas.*

**NOZZLE WEAR PLATE**

**P/N 890413.**

*Extends nozzle life when used along curbs and hard surfaces.*

**OPTIONAL DEBRIS BAGS**

**PRO FELT DEBRIS BAG**

**P/N 890023.**

*For use in dusty conditions.*

**PRO TURF AND WET WEATHER BAG**

**P/N 890028**

*For use in leaves and grass and non dusty conditions.*

**DEBRIS BAG COVER**

**P/N 900801** *Directs dust downward away from operator.*

**ZIPPERLESS QUICK BAG**

**P/N 890309** *For non dusty conditions that are damaging to zippers.*

**CASTER KIT**

**P/N 890412** *For use on hard surface*

1

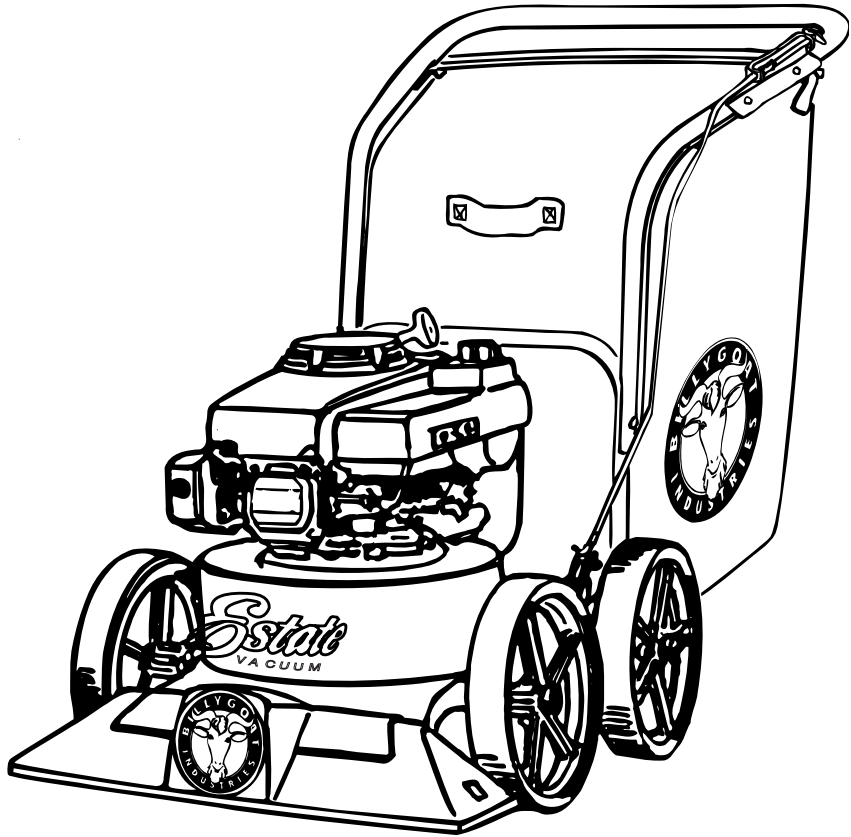

*Thank You for Selecting  
The Powerful KD VACUUM*

# Operator Owner's Manual

**KD 410**

3

## Specifications

**KD 410**

ENGINE:H.P.	4.0 (2.98kW)
ENGINE:TYPE	B&S
ENGINE:FUEL CAP.	1.0qt. (0.95L)
ENGINE:OIL CAP.	0.63qt. (0.6L)
WEIGHT:UNIT	103# (46.7 kg)
WEIGHT:SHIPPING	126# (57.2 kg)
ENGINE WEIGHT:	24.8# (11.05 kg)

**UNIT SIZE:** OVERALL LENGTH: 62"(1.57m) OVERALL WIDTH 26.75" (0.68m) OVERALL HEIGHT 42" (1.07m)

4

# IN THE INTEREST OF SAFETY



**BEFORE STARTING ENGINE, READ AND UNDERSTAND THE "ENTIRE OPERATOR'S MANUAL & ENGINE MANUAL."**



**THIS SYMBOL MEANS WARNING OR CAUTION. DEATH, PERSONAL INJURY AND/OR PROPERTY DAMAGE MAY OCCUR UNLESS INSTRUCTIONS ARE FOLLOWED CAREFULLY.**



**WARNING:** The Engine Exhaust from this product contains chemicals known to the State of California to cause cancer, birth defects or other reproductive harm.

## WARNING: DO NOT

1. **DO NOT** run engine in an enclosed area. Exhaust gases contain carbon monoxide, an odorless and deadly poison.
2. **DO NOT** place hands or feet near moving or rotating parts.
3. **DO NOT** store, spill or use gasoline near an open flame, or devices such as a stove, furnace, or water heater which use a pilot light or devices which can create a spark.
4. **DO NOT** refuel indoors where area is not well ventilated. Outdoor refueling is recommended.
5. **DO NOT** fill fuel tank while engine is running. Allow engine to cool for 2 minutes before refueling. Store fuel in approved safety containers.
6. **DO NOT** remove fuel tank cap while engine is running.
7. **DO NOT** operate engine when smell of gasoline is present or other explosive conditions exist.
8. **DO NOT** operate engine if gasoline is spilled. Move machine away from the spill and avoid creating any ignition until the gasoline has evaporated.
9. **DO NOT** transport unit with fuel in tank.
10. **DO NOT** smoke when filling fuel tank.
11. **DO NOT** choke carburetor to stop engine.
12. **DO NOT** run engine at excessive speeds. This may result in injury & /or damage to unit.

13. **DO NOT** tamper with governor springs, governor links or other parts which may change the governed engine speed.

14. **DO NOT** tamper with the engine speed selected by the engine manufacturer.

15. **DO NOT** check for spark with spark plug or spark plug wire removed. Use an approved tester.

16. **DO NOT** crank engine with spark plug removed.

17. **DO NOT** strike flywheel with a hard object or metal tool as this may cause flywheel to shatter in operation. Use proper tools to service engine.

18. **DO NOT** operate engine without a muffler. Inspect periodically and replace, if necessary. If engine is equipped with muffler deflector, inspect periodically and replace, if necessary, with correct deflector.

19. **DO NOT** operate engine with an accumulation of grass, leaves, dirt or other combustible material in the muffler area.

20. **DO NOT** use this engine on any forest covered, brush covered, or grass covered unimproved land unless a spark arrester is installed on the muffler. The arrester must be maintained in effective working order by the operator. In the State of California the above is required by law (Section 4442 of the California Public Resources Code).

Other states may have similar laws. Federal laws apply on federal lands.

21. **DO NOT** touch hot muffler, cylinder, or fins because contact may cause burns.

22. **DO NOT** run engine without air cleaner or air cleaner cover.

23. **DO NOT** operate during excessive vibration!

24. **DO NOT** leave machine unattended while in operation.

25. **DO NOT** park machine on a steep grade or slope.

## WARNING: DO

1. **ALWAYS DO** remove the wire from the spark plug when servicing the engine or equipment TO PREVENT ACCIDENTAL STARTING.

2. **DO** keep cylinder fins and governor parts free of grass and other debris which can affect engine speed.

3. **DO** pull starter cord slowly until resistance is felt. Then pull cord rapidly to avoid kickback and prevent hand or arm injury.

4. **DO** examine muffler periodically to be sure it is functioning effectively. A worn or leaking muffler should be repaired or replaced as necessary.

5. **DO** use fresh gasoline. Stale fuel can gum carburetor and cause leakage.

6. **DO** check fuel lines and fittings frequently for cracks or leaks. Replace if necessary

7. **Follow** engine manufacturer operating and maintenance instructions.

8. **Inspect** machine and work area before starting unit.

### 5 TABLE OF CONTENTS

<b>SAFETY INSTRUCTIONS</b> . . . . .	2
<b>GENERAL SAFETY</b> . . . . .	3
<b>ASSEMBLY</b> . . . . .	3
<b>LABELS</b> . . . . .	4
<b>OPERATION</b> . . . . .	5
<b>PARTS DRAWING &amp; LIST</b> . . . . .	6 - 7
<b>MAINTENANCE</b> . . . . .	7 - 8
<b>TROUBLESHOOTING</b> . . . . .	8
<b>WARRANTY PROCEDURE</b> . . . . .	8



**THE BRIGGS AND STRATTON ENGINE ON THIS EQUIPMENT CANNOT BE SOLD IN THE STATE OF CALIFORNIA.**

6

### SOUND

Sound tests conducted were in accordance with 2000/14/EEC and were performed on 2/21/2002 under the conditions listed:

**NOTE:** Sound power level listed is the highest value for any model in this manual. Please refer to serial plate on the unit for the sound power level for your model.

Sound level of 98 dBA at operator position



GENERAL CONDITION:	Sunny
TEMPERATURE:	45° F (7.2° C)
WIND SPEED:	5 MPH (8.1 kmh)
WIND DIRECTION:	South West
HUMIDITY:	60 %
BAROMETRIC PRESSURE:	30.18" Hg (767mm Hg)

7

### VIBRATION

VIBRATION LEVELS 2.0g

Vibration levels at the operators handles were measured in the vertical, lateral, and longitudinal directions using calibrated vibration test equipment. Tests were performed on 11/20/98 under the conditions listed:

GENERAL CONDITION:	Sunny
TEMPERATURE:	50° F (10.0° C)
WIND SPEED:	8 MPH (12.9 kmh)
WIND DIRECTION:	west
HUMIDITY:	54 %
BAROMETRIC PRESSURE:	30.23" Hg (768mm Hg)

## GENERAL SAFETY

*For your safety and the safety of others, these directions should be followed:*

 Do not operate this machine without first reading owner's manual and engine manufacturer's manual.

 Use of Ear Protection is recommended while operating this machine.

 Use of Eye and Breathing protection is recommended when using this machine, especially in dry and dusty conditions. Optional bag cover directs dust toward ground, away from the operator.

•DO NOT place hands or feet inside nozzle intake opening, near debris outlet or near any moving parts.

•DO NOT start engine without debris bag and quick disconnect connected firmly in place to exhaust outlet.

•DO NOT start or operate machine with debris bag zipper open.

•DO NOT operate during excessive vibration.

•DO NOT remove bag until engine has been turned off and has come to a complete stop.

•DO NOT remove hose kit cap on nozzle until engine has been turned off and has come to a complete stop.

•DO NOT operate machine with hose cap, bag or hose removed.

•DO NOT use this machine for vacuuming **exclusively** sand, dust, fine dirt, rock, glass, string like material, grain, rags, cans, metal, bark or water.

•DO NOT operate this machine on slopes greater than 20%.

•DO NOT pick up any hot or burning debris, or any toxic or explosive material.

•DO NOT allow children to operate this equipment.

## ASSEMBLY



Read all safety and operating instructions before assembling or starting this unit.



PUT OIL IN ENGINE BEFORE STARTING

Your Billy Goat is shipped from the factory in one carton, completely assembled except for the upper handle, debris bag, and bag quick disconnect.

1. **ASSEMBLE** Lift upper handle (item 6), remove items 8, 74, & 30 from lower handle (item 27). Attach upper and lower handle as shown, and securely tighten nuts (item 74).

2. **UNFOLD** the debris bag (item 1) and fasten bag neck to bag quick disconnect (item 83). Attach firmly to housing exhaust (item 52) see fig. 2.

3. **ATTACH** bag hanger strap to bag supports (item 11), preassembled to upper handle.

5. **CONNECT** spark plug wire.

## PACKING CHECKLIST

These items should be included in your carton. If any of these parts are missing, contact your dealer.

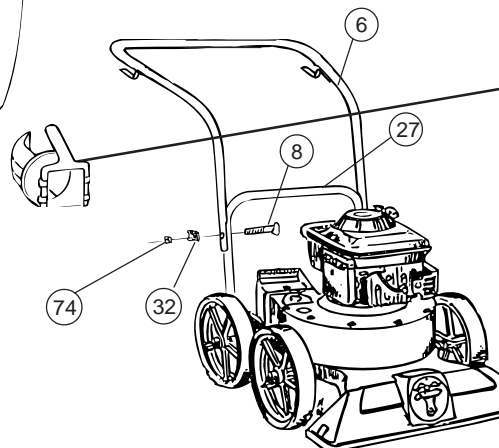
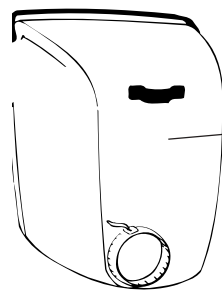

Check <input type="checkbox"/>	Debris Bag 890304 KD
Check <input type="checkbox"/>	Connector Quick Disconnect 890176
Check <input type="checkbox"/>	Literature Assy 890454
Check <input type="checkbox"/>	<i>Per Model</i> Briggs & Stratton MS9984 Multi-Language

Literature  
Assembly

Engine  
Manual

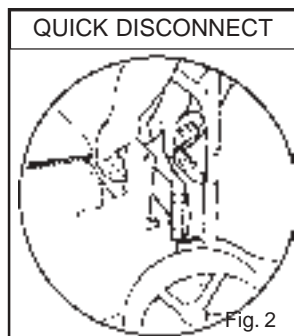

**11 LITERATURE ASSY P/N 890454**

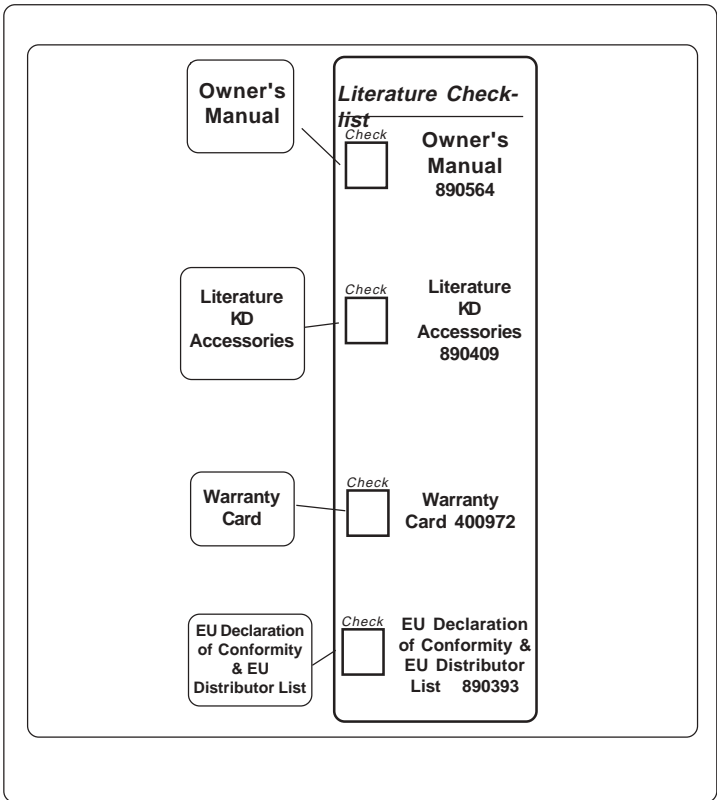

**12 INSTRUCTION LABELS**

These labels should be included on your Vacuum. If any of these labels are damaged, replace them before putting this equipment into operation. Item and part numbers are given to help in ordering replacement labels..



**Label Danger**  
Keep Hands and Feet Away  
Item 29 Part No.400424



**Label Read Owner's Manual**  
Item 84  
Part No.890301



**Label Danger Flying Material**  
Item 62 Part No.810736

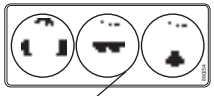

**Label Ear Eye Breathing**  
Item No. 86 Part No. 890254

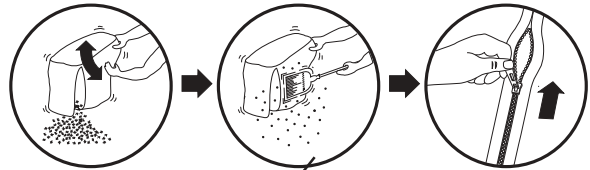

**Debris Bag**  
Label item 1

**13 ENGINE LABELS**

**3x PUSH TO PRIME**

**STOP START**

**IN U.S.A. USE UNLEADED GASOLINE ONLY**

**WARNING**

- Read and follow Operating Instructions before running engine.
- Gasoline is flammable. Allow engine to cool at least 2 minutes before refueling.
- Engines emit carbon monoxide, DO NOT run in enclosed area.

# Operation

**INTENDED USE:** This machine is designed for vacuuming leaves, grass clippings and other types of organic litter.

Debris mixed with cans, bottles and small amounts of sand can be vacuumed; however, it is not this machine's primary purpose. Vacuuming cans, bottles and sand will affect the longevity of your machine.

Do not operate if excessive vibration occurs. If excessive vibration occurs, shut engine off immediately and check for damaged or worn impeller, loose impeller bolt, loose impeller key, loose engine or lodged foreign objects. Note: See parts list for proper impeller bolt torque specifications. (See trouble shooting section on page 8).



Like all mechanical tools, reasonable care must be used when operating machine.

**Inspect machine work area and machine before operating. Make sure that all operators of this equipment are trained in general machine use and safety.**



**PUT OIL IN ENGINE BEFORE STARTING.**

14.1

## STARTING



**ENGINE:** See engine manufacturer's instructions for type and amount of oil and gasoline used. Engine must be level when checking and filling oil and gasoline.

**FUEL VALVE:** Move fuel valve to "ON" position (when provided on engine).

**PRIMER:** Push primer per engine instructions.

**IF YOUR UNIT FAILS TO START:**

See Troubleshooting on page 8.

14.2

## VACUUMING OPERATION

**VACUUM NOZZLE HEIGHT ADJUSTMENT:** is raised and lowered by pulling slightly upward on handle and pulling height adjust control (item 23) out on left side of handle. (Note: Top notch is intended for use with hose kit to cut off intake air.)

**FOR MAXIMUM PICKUP:** Adjust nozzle close to debris, but without blocking airflow into the nozzle. *NOTE:* Never bury nozzle into debris.



### CLEARING A CLOGGED NOZZLE



**& EXHAUST:** Turn engine off and wait for impeller to stop completely and disconnect spark plug wire. Wearing durable gloves, remove clog. **Danger,** the clog may contain sharp materials. Reconnect spark plug wire.

14.10

## COMPOST

Vacuumed leaves, grass and other organic material from your own yard can be emptied into a pile or composter to provide enriched soil for later use as fertilizer in gardens and flower beds (see fig. 3).

Note: Allow green chips to dry before spreading around living plants.

14.3

## DEBRIS BAG

**Debris bags are normal replaceable wear items.**



**Note:** Frequently empty debris to prevent bag overloading with more weight than you can lift.

An optional bag and dust cover is available for use where debris will be vacuumed in dusty conditions (see **Optional Accessories shown on page 1**).

**DO NOT place bag on or near hot surface,** such as engine. Your new bag requires a break-in period to condition the pores of the material against premature blockage. The entire bag surface serves as a filter, and must be able to breath to have good vacuum performance.

Be sure engine has come to a complete stop before removing or emptying bag.

**This vacuum is designed for picking up trash, organic material and other similar debris** (see Safety Warnings page 2-3). However, many vacuums are used where dust is mixed with trash. Your unit can intermittently vacuum in dusty areas. Dust is the greatest cause of lost vacuum performance. However, following these rules will help maintain your machine's ability to vacuum in dusty conditions:

- The debris bag must be cleaned more frequently. A vacuum with a clean, pillow soft bag will have good pickup performance. One with a dirty, tight bag will have poor pickup performance. If dirty, empty debris and vigorously shake bag free of dust.
- Machine or pressure-wash debris bag if normal cleaning does not fully clean bag. Bag should be thoroughly dry before use.

*Having one or more spare debris bags is a good way to reduce down time while dirty bags are being cleaned.*

- DO NOT** leave debris in bag while in storage.

14.4

## HANDLING & TRANSPORTING:

Using two people to lift machine is recommended. Lift holding the handle and front of nozzle. Secure in place during transport.

14.5

## STORAGE



Never store engine indoors or in enclosed poorly ventilated areas with fuel in tank, where fuel fumes may reach an open flame, spark or pilot light, as on a furnace, water heater, clothes dryer or other gas appliance.

**If engine is to be unused for 30 days or more, prepare as follows:**



Be sure engine is cool. Do not smoke. Remove all gasoline from carburetor and fuel tank to prevent gum deposits from forming on these parts and causing possible malfunction of engine. Drain fuel outdoors, into an approved container, away from open flame. Run engine until fuel tank is empty and engine runs out of gasoline.

**NOTE:** Fuel stabilizer (such as Sta-Bil) is an acceptable alternative in minimizing the formation of fuel gum deposits during storage. Add stabilizer to gasoline in fuel tank or storage container. Always follow mix ratio found on stabilizer container. Run engine at least 10 min. after adding stabilizer to allow it to reach the carburetor.



**Do not store with debris in bag.**

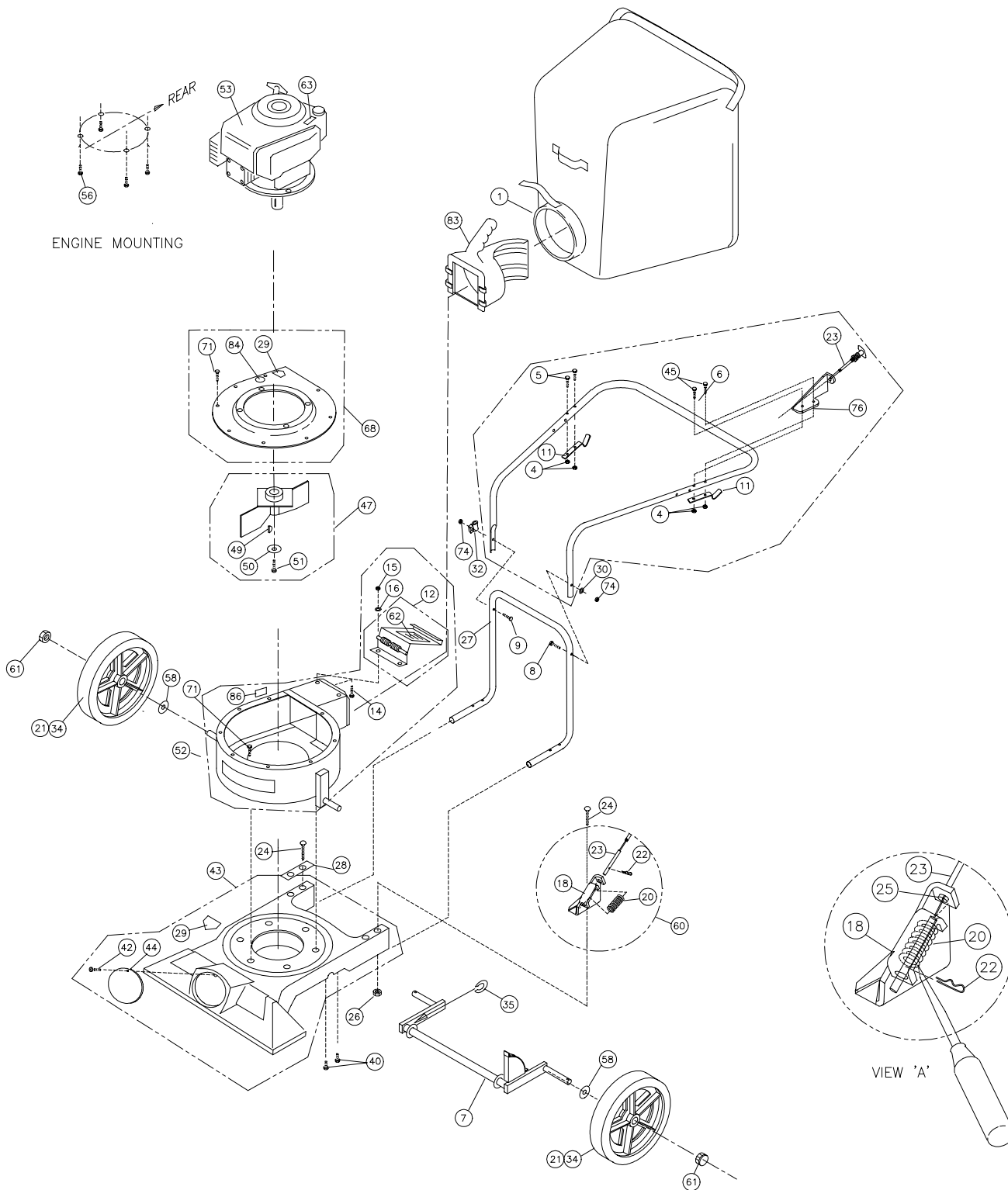

**15 PARTS DRAWING**

**KD410**



Item No.	16 PARTS LIST	Description	KD410 Part No.	QTY
1	TURF QUICK DEBRIS BAG (SEE ACCESSORIES FOR OTHER OPTIONS)		890305	1
4	NUT LOCK (1/4 - 20)		*8160001	6
5	SCREW CAP ( 1/4 - 20 x 1-1/2 HEX )		*8041008	4
6	HANDLE ASS'Y (incl. items 5(5),11(2))		900054	1
7	AXLE HEIGHT ADJUST		890389	1
8	SCREW HANDLE 5/16 - 18 x 1 3/4		*8041031	1
9	SCREW HANDLE 5/16 - 18 x 2 1/2		*8041034	1
11	BAR BAG SUPPORT		900039	2
12	DOOR EXHAUST ASS'Y (incl. item 62 )		890148	1
14	BOLT-CARRIAGE 1/4x3/4		*8024021	2
16	WASHER 1/4 FC ZP		*8171002	2
18	BRACKET - HEIGHT ADJUSTMENT		890021	1
20	SPRING		900136	1
21	TIRE - ONLY (PER ASSY)		900507	1
22	PIN - HAIR COTTER		900471	1
23	CABLE HEIGHT ADJUSTMENT		890019	1
24	BOLT - CARRIAGE 5/16 - 18 x 4 1/2		*8024054	4
26	NUT LOCK 5/16 - 18 HEX		*8160002	4
27	HANDLE LOWER KD510		890346	1
28	PLATE HANDLE SUPPORT		900933	1
29	LABEL DANGER CUT FINGER		400424	2
30	WASHER FLAT CUT 5/16		*8171003	2
32	ROPE GUIDE		830533	2
34	WHEEL ASS'Y (incl. items 21)		900509	4
35	WASHER 0.75 "C"		900997	0-1
40	SCREW CAP 1/4 - 20 x 1 - 1/4		*8041007	4
42	SCREW SELF TAPPING 10 - 24 x 1/2		*8123086	1
43	NOZZLE MAINFRAME ASS'Y (incl. one of items 29,44,42)		890391	1
44	PLUG		900146	1
45	SCREWCAP 1/4-20 X 1 3/4		8041009	1
47	IMPELLER ASS'Y (incl. items 49, 50, 51, 59 )		900168	1
49	KEY		900162	2
50	WASHER LOCK 3/8 TWISTED TOOTH		400502	1
51	SCREW CAP 3/8 -24 x 1 (HARDENED)(TORQ.50 FT-LBS)(68N.m)		900154	1
52	HOUSING ASS'Y (incl. items 12, 14, 15, 16, 86)		890371	1
53	ENGINE BRIGGS AND STRATTON 4 HP QUATTRO		890565	1
56	SCREW CAP 3/8 - 1-1/2 TAPTITE		890408	3
58	WASHER FLAT 1/2 SAE		*8172011	4
60	HT ADJUST ASSY		890013	1
61	1/2-13 CAP NUT NP W/PATCH		890530	4
62	LABEL DANGER FLYING MATERIAL		810736	1
63	LABEL DO NOT FILL WHEN ENGINE IS HOT		400268	1
68	PLATE TOP ASS'Y (incl. items 14, 15, 29, 48, 69, 70, 71, 72)		890402	1
71	SCREW CAP 1/4 - 20 x 1/2 HWH		890359	15
74	NUT LOCK 5/16 - 18 THIN HT.		*8161041	2
76	PLATE UPPER HEIGHT ADJUST		890005	1
83	CONNECTOR BAG QUICK		890176	1

\* Denotes standard hardware item that may be purchased locally.

17

## MAINTENANCE



Use only a qualified mechanic for any adjustments, disassembly or any kind of repair .



**WARNING: TO AVOID PERSONAL INJURY, ALWAYS TURN MACHINE OFF, MAKE SURE ALL MOVING PARTS COME TO A COMPLETE STOP.**



**DISCONNECT SPARK PLUG WIRE BEFORE SERVICING UNIT.**



ENGINE: See engine manufacturer operator's instructions.

**DEBRIS BAG:** See page 5.



**RECONNECT SPARK PLUG WIRE, GUARDS, BAG, CAPS AND / OR HOSE BEFORE STARTING ENGINE.**

### 17.1 IMPELLER REMOVAL

1. Wait for engine to cool and disconnect spark plug.
2. Drain fuel and oil from the engine.
3. Remove bag, quick release, and upper handle.
4. Remove housing top plate by removing bolts around outside of housing.
5. Leaving engine fastened to top plate, remove impeller bolt and lock washer and slide impeller off crankshaft (A puller may be required).
6. If impeller slides off freely, proceed to step 9. **(Do not drop impeller).**
7. If impeller does not slide off crankshaft, place two crowbars between impeller and housing on opposite sides. Pry impeller away from engine until it loosens. *Using a penetrating oil can help loosen a stuck impeller.*
8. If the impeller cannot be loosened, obtain a 1" (25.4mm) longer bolt of the same diameter and thread type as the impeller bolt. Invert engine and impeller and support engine above ground to prevent recoil damage. Thread longer bolt by hand into the crankshaft until bolt bottoms. Using a suitable gear or wheel puller against the bolt head and the impeller back-plate (near the blades), remove impeller from shaft.

**17 MAINTENANCE** continued

**17.1 IMPELLER REMOVAL** continued

**9.** To reinstall impeller, use a new impeller bolt and lockwasher and use exactly the same crankshaft impeller shim washers as were removed during disassembly (unless they were damaged). **Note:** *your unit may or may not have required the use of shim washers.*

**10.** Tighten impeller bolt. Torque impeller bolt to 50 Ft. Lbs. (68 N·m) (see item 51 on page 11).

**11.** Reinstall engine and impeller onto housing in reverse order of removal.

**12.** Before connecting spark plug wire, slowly pull engine starting rope to insure that impeller rotates freely.

**13.** Reinstall spark plug wire.

**MAINTENANCE HISTORY**

Date of Service	Service Performed

**17.2 Maintenance Schedule** Follow these hourly maintenance intervals.

Maintenance Operation	Every Use	Every 5 hrs or (Daily)
Engine (See Engine Manual)		
Check for excessive vibration		●
Clean Debris Bag	●	
Check bag strap tightness	●	
Inspect for loose parts		●
Inspect for worn or damaged parts		●

**18 TROUBLESHOOTING** Before Requesting Service Review These Suggestions

Problem	Possible Cause	Solution
Will not vacuum or has poor vacuum performance.	Dirty debris bag. Nozzle height set too high or too low. Hose kit cap missing. Clogged nozzle or exhaust. Excessive quantity of debris.	Clean debris bag. Shake bag clean or wash. Adjust nozzle height. Check for hose kit cap. Unclog nozzle or exhaust (see page 5). Allow air to feed with debris.
Abnormal vibration.	Loose or out of balance impeller or loose engine.	Check impeller and replace if required. Check Engine.
Engine will not start.	Out of gasoline. Bad or old gasoline. Spark Plug wire disconnected. Dirty air cleaner. Safety Interlock engaged.	Check gasoline. Connect spark plug wire. Clean or replace air cleaner. Or contact a qualified service person. Quick Disconnect not fully engaged.
Engine is locked, will not pull over.	Engine problem.	Contact an engine servicing dealer for engine problems.

**20.1 Engine Service and Warranty** Contact your nearest engine manufacturer's authorized servicing dealer.

**19 Serial Plate** Record your machine model, serial number and date-of-purchase and where purchased



**BILLY GOAT INDUSTRIES, INC.**

1803 S. Jefferson  
P.O. Box 308  
Lee's Summit,  
MO 64063 / USA  
Tel (816) 524-9666  
Fax (816) 524-6983



Model Serial No.

Unit (Weight) Engine Power

lbs.
kg

kW
rpm

Purchase Date \_\_\_\_\_ Purchased from \_\_\_\_\_

**20 WARRANTY PROCEDURE**

Please fill in the WARRANTY CARD and send the upper part to Billy Goat. The WARRANTY terms are stated on the lower part which remains with the user. Whenever a Billy Goat Machine is faulty due to a defect in material and / or workmanship, the owner should make a warranty claim as follows:

The Machine should be taken to the dealer from whom it was purchased or to an authorized Billy Goat dealer.

The owner should present the remaining half of the Warranty Registration Card, or, if this is not available, the invoice or receipt.

The Warranty Claim will be filled in by the authorized Billy Goat Dealer, who will send it with the faulty part to Billy Goat headquarters.

The Quality / Service department at Billy Goat headquarters will study the claim and parts and will notify their conclusions.

The decision by the Quality / Service department at Billy Goat headquarters to approve or reject a Warranty claim is final and binding.

*Note:* To process a Warranty Claim, it is necessary to quote the Model & Serial number who are printed on the Billy Goat Serial Plate.

**BILLY GOAT** **BILLY GOAT INDUSTRIES INC.**  
1803 S JEFFERSON LEE'S SUMMIT, MO 64082 / USA  
PHONE: 816-524-9666 FAX: 816-524-6983 www.billygoat.com