

BILLY GOAT

INDUSTRIES, INC.



vacuum cleaner

Model No. KD-50 S.P., KD-50 S.P.T (Self Propelled)

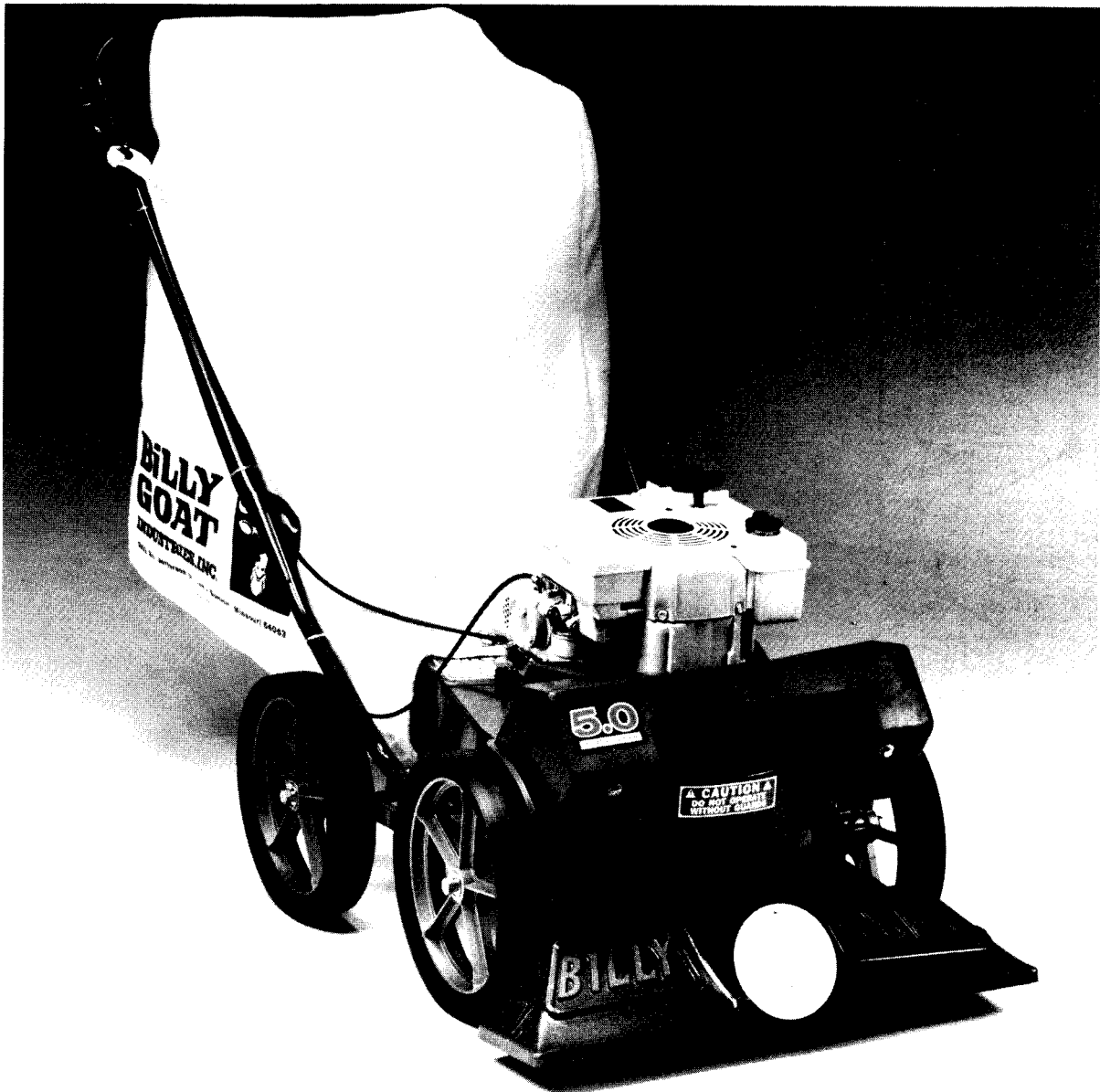

OWNER'S MANUAL

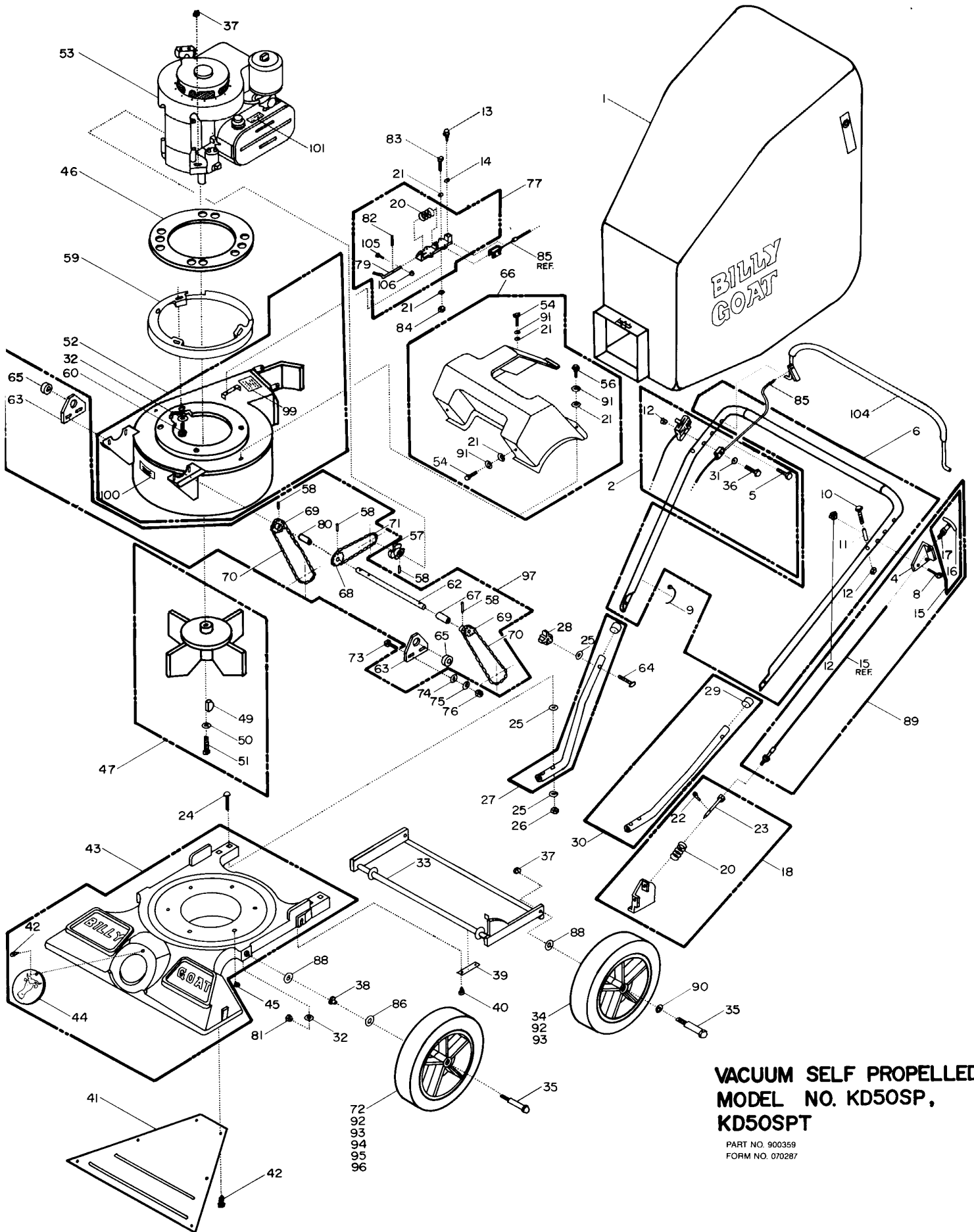

**VACUUM SELF PROPELLED
MODEL NO. KD5OSP,
KD5OSP**

PART NO. 900359
FORM NO. 070287

KD-50 S.P., KD-50 S.P.T. PARTS LIST

ITEM NO.	DESCRIPTION	KD-50 S.P.		KD-50 S.P.T.		ITEM NO.	DESCRIPTION	KD-50 S.P.		KD-50 S.P.T.	
		PART NO.	QTY.	PART NO.	QTY.			PART NO.	QTY.	PART NO.	QTY.
1	Dust Bag (Felt) □	900650	1	900650	1	55					
2	Throttle Ass'y (includes items, (qty), 5(1), 12(2), 31(1), 36(1))	900210	1	900210	1	56	Screw 1/4" N.C. x 1/2	*8041002	1	*8041002	1
3						57	Clutch-Double Release	900307	1	900307	1
4	Bracket	900144	1	900144	1	58	Roll Pin 3/16 Dia. x 1 1/4 Lg.	*8195166	4	*8195166	4
5	Screw Mach. No. 10-24 x 1 3/4 Hex W.F.	*8059142	1	8059142	1	59	Spacer Ring Full Ass'y	900304T	1	900304T	1
6	Handle Assembly (incl. 2 ea. of items 10, 11, 12)	900563	1	900563	1	60	Capscrew 3/8 NC x 2 1/2 Hex Hd.	900564	3	900564	3
7						61					
8	Screw Machine, No. 10-24 NC x 1 1/4 Hex Hd.	*8059140	2	*8059140	2	62	Jackshaft	900320	1	900320	1
9	Ty Rap	900407	4	900407	4	63	Bearing Plate	900317	2	900317	2
10	Machine Screw, No. 10-24 NC x 2" Lg. Hex Hd.	*8059143	2	*8059143	2	64	Screw-Handle 5/16 NC x 2 1/4	900547	2	900547	2
11	Rubber Grommet	900141	2	900141	2	65	Bearing-Ball With Snap Ring	900321	2	900321	2
12	Locknut No. 10-24 NC Hex.	*8164005	6	*8164005	6	66	Chain Guard Ass'y (Includes 55, 54, 56, 21, 91)	900218	1	900218	1
13	Screw No. 10-24 x 1/2 Hex. Self Thd.	*8123086	1	*8123086	1	67	Spacer-Short	900306	1	900306	1
14	Washer No. 10 SAE (7/32 I.D. x 1/2 O.D. x 1/16)	*8172005	1	*8172005	1	68	Sprocket-17T	900303	1	900303	1
15	Control Cable Ass'y (Includes 16 and 17)	900145	1	900145	1	69	Sprocket-8T	900302	2	900302	2
16	Handle and Cable	900145-01	1	900145-01	1	70	Chain 48P	900324	2	900324	2
17	Sleeve and Hardware	900145-02	1	900145-02	1	71	Chain 40P	900323	1	900323	1
18	Lock Assembly	900142	1	900142	1	72	Wheel W/18T Ass'y Cast (Incl. 92, 93, 94, 95, 96)	900512	2	900512	2
19						73	Bolt-Carriage 5/16 NC x 3/4 "	*8024039	4	*8024039	4
20	Spring	900136	2	900136	2	74	Washer Flat 5/16 (3/8 I.D. x 7/8 O.D. x 1/16)	*8171003	4	*8171003	4
21	Washer 1/4" Flat (5/16 I.D. x 3/4 O.D. x 1/16)	*8171002	8	*8171002	8	75	Lock Washer-5/16" Spring	*8177011	4	*8177011	4
22	Hairpin Cotter	900471	1	900471	1	76	Nut 5/16" NC Hex.	*8142002	4	*8142002	4
23	Plunger Assembly	900138	1	900138	1	77	Bracket Control Ass'y (incl. 78, 79, 20, 82, 105, 106)	900221	1	900221	1
24	Carriage Bolt 5/16-18 NC x 1 3/4 Lg.	*8024043	4	*8024043	4	78					
25	Washer 5/16" SAE (11/32 I.D. x 11/16 O.D. x 1/16)	*8172008	10	*8172008	10	79	Rod Clutch	900208	1	900208	1
26	Locknut 5/16"-18 NC Hex	*8160002	4	*8160002	4	80	Spacer-Long	900305	1	900305	1
27	Handle Stub Ass'y (R.H.) (includes item 29)	900584	1	900584	1	81	Nut Lock 3/8 NC Thin Ht.	8161042	2	8161042	2
28	Hand Knob	900456	2	900456	2	82	Roll Pin 1/8" Dia. x 1-1/2" Lg.	*8195108	1	*8195108	1
29	Cap End 1" I.D.	800392	2	800392	2	83	Cap Screw 1/4" NC x 1" Lg. Hex.	*8041006	2	*8041006	2
30	Handle Stub Ass'y (L.H.) (includes item 29)	900585	1	900585	1	84	Nut Lock 1/4 NC Hex	*8160001	2	*8160001	2
31	Washer F.C. No. 10 (1/4 x 3/16 x 3/64)	*8171001	1	*8171001	1	85	Cable Ass'y-Clutch	900207	1	900207	1
32	Washer Lock 3/8 Int.	*8180011	5	*8180011	5	86	Washer 1/2 (17/32 I.D. x 1 1/16 O.D. x 3/32)	*8172011	2	*8172011	2
33	Rear Axle Frame Weldment +	900565	1	900565	1	87					1
34	Wheel Ass'y Cast (Incl. 92, 93) 12" x 2.5" Offset	900509	2	900509	2	88	Washer Flat 3/8 (13/32 I.D. x 3/4 O.D. x 1/16) +	*8172018	4	*8172018	4
35	Shoulder Bolt	800508	4	800508	4	89	Control Assembly HT.-Adj. (Includes 15, 4, 8, 12)	900155	1	900155	1
36	Screw Mach. No. 10-24 NC x 2 1/4	*8059144		*8059144	1	90	Washer-KD Wheel Mtg.	900230	2	900230	2
37	Nut 3/8-16 NC Hex Lock +	*8160003	5	*8160003	5	91	Washer Lock 1/4	*8177010	4	*8177010	4
38	Spacer	900385	2	900385	2	92	Tire-Only (Per Assembly)	900507	1	900507	1
39	Hold Down Plate (Rear Axle)	900123	2	900123	2	93	Bearing Only (Per Assembly)	900498	2	900498	2
40	Screw 1/4" A.B. x 3/4" Lg. Sheet Metal	*8122082	4	*8122082	4	94	Sprocket (Per Assembly)	900501	1	900501	1
41	Bottom Cover	900121	1	900121	1	95	Screw Tap 1/4-14 x 3/4 (Per Assembly)	900505	5	900505	5
42	Screw No. 10-24 NC x 1/2 Lg. Self Tapping	*8123086	7	*8123086	7	96	Washer-Lock Ext. 1/4 (Per Assembly)	*8181007	5	*8181007	5
43	Main Frame Ass'y (incl. 1 ea. of items 42, 44)	900579	1	900579	1	97	Jackshaft Ass'y (Includes 58, 62, 63, 65, 67, 68, 69)	900322	1	900322	1
44	Plug	900146	1	900146	1	98					
45	Locknut 5/16"-18 NC Hex Lt. Wt. Thin	*8161041	6	*8161041	6	99	Label Hands and Feet	900326	1	900326	1
46	Gasket	800411	1	800411	1	100	Label - Caution Guards	900327	1	900327	1
47	Impeller-Assembly (Includes 49, 50, 51)	900342	1	900342	1	101	Label - Do Not Fill	400268	1	400268	1
48						102					
49	Key-Woodruff No. 6 (5/32 x 5/8)	900162	2	900162	2	103					
50	Lockwasher 3/8" Spring	*8177012	1	*8177012	1	104	Rod Bail Clutch Ass'y (includes grip)	900587	1	900587	1
51	Cap Screw (Hardened) 3/8" N.F. x 1 1/2" Hex	900344	1	900344	1	105	Screw Mach. No. 6 x 3/4 Lg. Hex Washer Face GR.5	*8120032	1	*8120032	1
52	Housing Assembly (includes 1 each of items 61, 84, 87, 99, 100)	900586	1	900586	1	106	Nut-Lock No. 6	*8164003	1	*8164003	1
53	Engine	900308	1	900308T	1						
54	Capscrew 1/4 NC x 3/4	*8041004	3	*8041004	3						

*Standard Hardware Item-May Be Purchased Locally.
+ New Axles, Item 33, Serial Nos. 35101 Thru 35600 & 36074 & Up
□ Service Zipper No. 900478

PART NO. 900359